

SPECIFICATION FOR BUILDER'S SKIP

1. Builder's skip means a container designed to be carried on a road vehicle and to be placed on a highway or other land for the storage of builder's materials or the removal and disposal of builder's rubble, waste, household and other rubbish or earth and shall comply with the appropriate Department of the Environment Construction and Use Regulations.
2. The builder's skip shall not exceed 5m in length by 2m width.
3. Builder's skip shall comply with the Traffic Signs Manual, Chapter 8, Appendix 3. Both ends of the builder's skip shall be painted yellow and signed with two reflectorized plates as per schedules 1 and 2 of The Builders' Skips (Marking) Regulations 1984, see attached (ie 4 reflectorised plates in total, 2 on each end).
4. Provision shall be made for at least four yellow lights (one at each corner) to be fixed securely to the skip.
5. The builder's skip shall be clearly and permanently be marked with the owner's name and telephone number and 24 hour emergency telephone number on the side of the skip.

SCHEDULE 2

(Regulation 3)

Requirements as to markings:

1. The marking specified in Schedule 1 shall consist of two plates of equal size and the same as one another.
2. Each such plates shall comply with the requirements specified in the British Standard Specification for Rear Marking Plates of Vehicles issued by the British Standards Institution and published on 1 April 1970 under number BS AU 152: 1970 and shall be marked as provided in paragraph 5 of that Standard.
3. The two plates comprising the marking shall be securely attached to the end of the builder's skip in such a manner that:
 - (a) each plate is as near to an outer edge of the skip as the construction of the skip allows, so, however, that no part of any plate projects beyond an outer edge of the end of the skip;
 - (b) the innermost edge of each plate is parallel to and the same distance from the vertical plane passing through the longitudinal axis of the skip;
 - (c) the upper edge of each plate is parallel to and the same distance from the upper edge of the end of the skip;
 - (d) no part of either plate is attached to –
 - (i) any lid, or
 - (ii) any door except in a case where a door is the only place to which they can possibly or conveniently be fixed; and
 - (e) the upper edge of each plate is –
 - (i) not more than 1.5 metres from the ground, and
 - (ii) not lower than the upper edge of the skip save in so far as this may be necessary on account of the construction of the skip, the provisions of Regulation 4 or the provision of subparagraph (i) above.
4. The stippled areas in the diagram in Schedule 1 shall be of red fluorescent material, and the unstippled areas in that diagram shall be of yellow reflecting material.

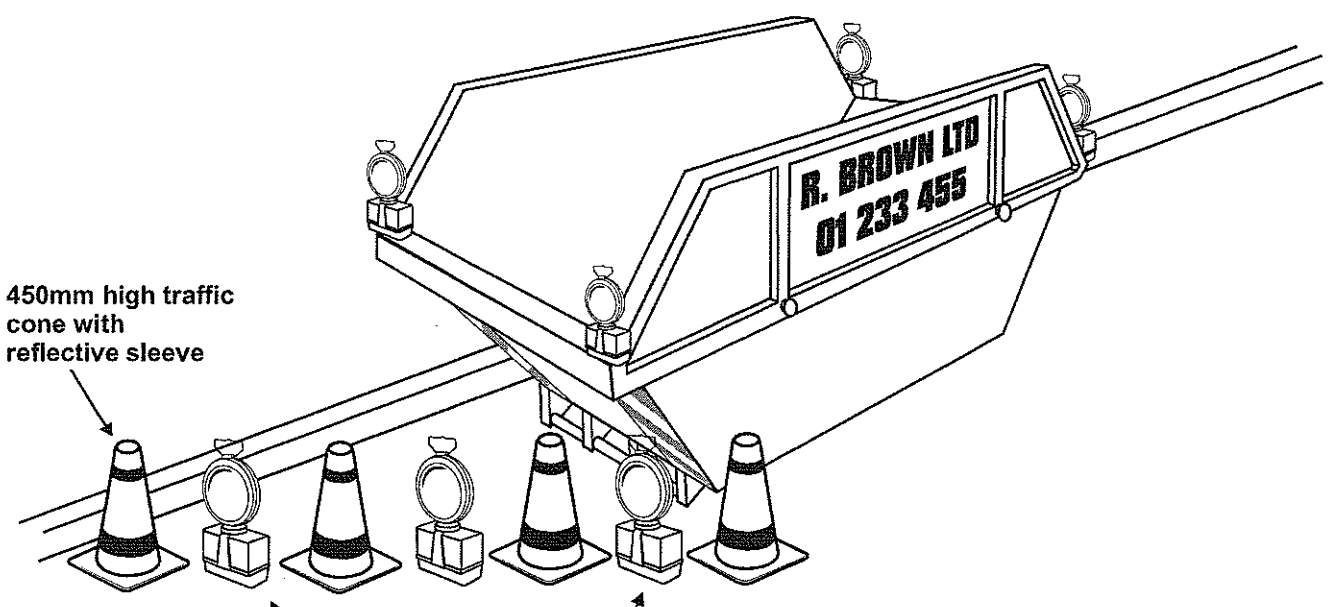
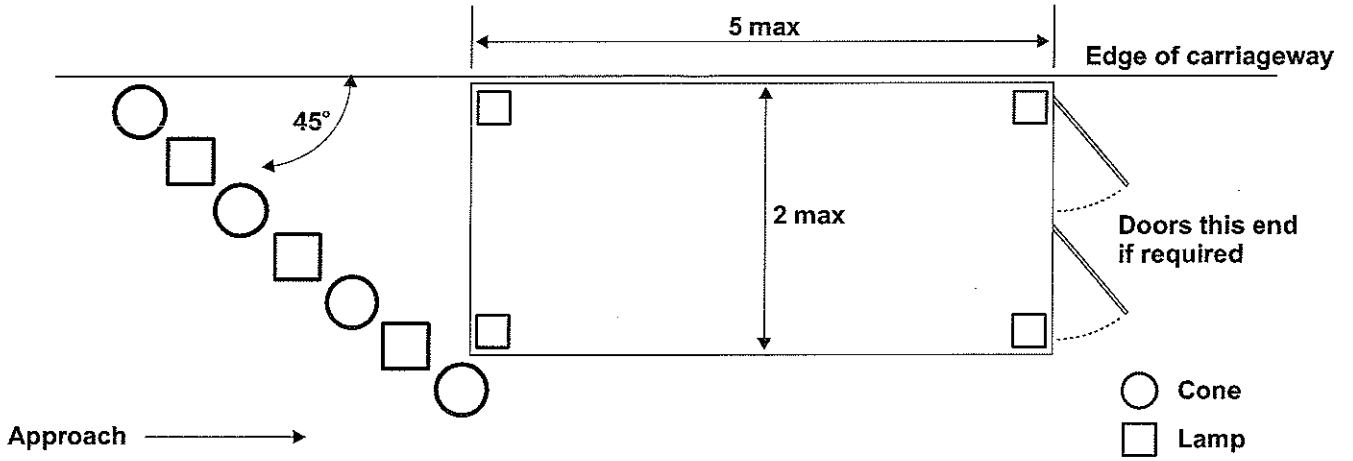

Note: These road lamps are still required in streets with street lighting

Note: Dimensions are in metres

